



Life Sciences

USD 2775

PKP Chromatography Systems



Delivering process-scale performance and enabling true linear scale up at pilot scale

The ability to transition from pilot-scale chromatographic processes to final process-scale without loss in separation performance is the foundation of Pall's PKP chromatography systems. The easy-to-use software and flexible component combinations, along with the precision instrumentation, enables systems that encompass a flow range of 1 to 150 L/h, for optimum gradient performance and true linear scale-up in a compact footprint.

Key Features

- ▣ Modular system design
- ▣ Scaleable automation and design
- ▣ Stainless steel construction- cGMP compliant
- ▣ Minimized hold-up volume
- ▣ Full system drainability
- ▣ Dual 4-piston diaphragm pumps
- ▣ Optimized clean-in-place (CIP) design

Filtration. Separation. Solution.SM

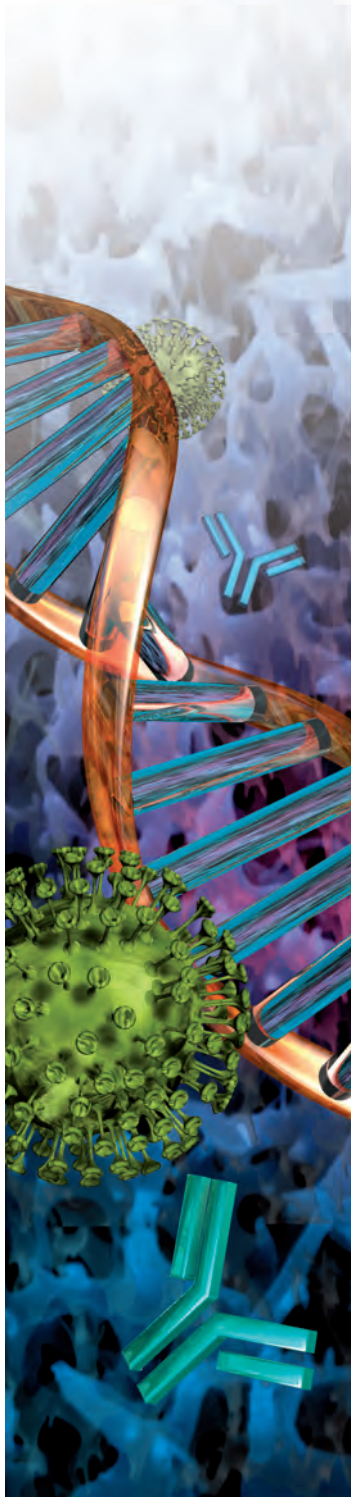

Applications

Pall's PKP chromatography products, a family of standard modular automated systems, are designed to perform all types of low pressure column biochromatography (e.g., ion exchange, affinity, mixed mode, hydrophobic interaction, size exclusion and hydroxyapatite) and membrane chromatography. These systems are suitable for small-scale production or process optimization, in addition to manufacturing biotherapeutic molecules according to GAMP guidelines.

System Overview

Figure 1

Base Unit System Overview

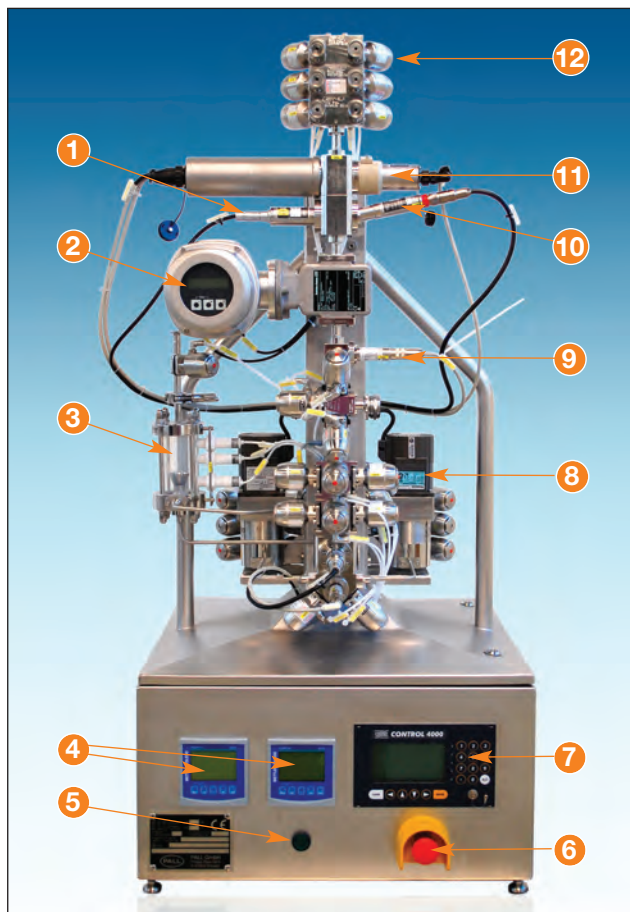

1. Conductivity meter
2. Flow meter
3. Bubble trap [option]
4. Display panels of conductivity, temperature, and pH measurement
5. Reset button
6. Emergency stop button
7. Display panel of the UV measuring instrument
8. Pump
9. Pressure sensor (post column) [option]
10. pH meter
11. UV instrument
12. Fraction outlets

Figure 2

PKP System Layout

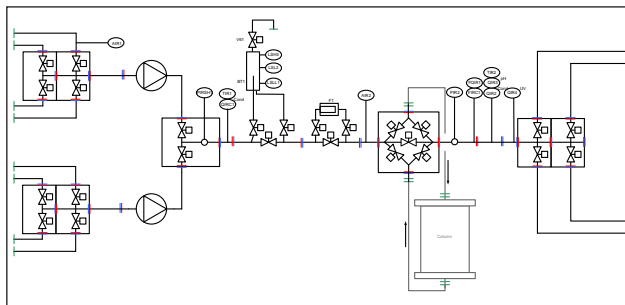

PKP System Automation Software Controls

- ▢ Intuitive recipe creation enables smoother scale up
- ▢ Batch or semi-automated mode allows users greater flexibility during operation
- ▢ Rapid instrument response provides clear visual display of process conditions, set points, and alarms
- ▢ Pall analytic tool enables calculation of HETP, peak asymmetry, transition analysis, etc.
- ▢ Comparison of different batches to monitor process reproducibility
- ▢ Selection individual instrument curves enables greater flexibility in batch data reporting for regulatory submissions
- ▢ 21 CFR part 11 compliance

Figure 3

Pall Analytic Tool

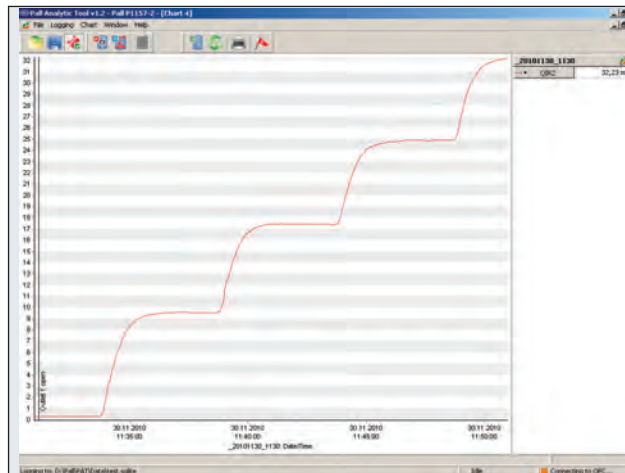

Pall analytic tool enables calculation of column evaluation parameters such as: HETP, peak asymmetry, and transition analysis. Configurable to meet user requirements for batch data reporting and comparison.

Figure 4
Recipe management

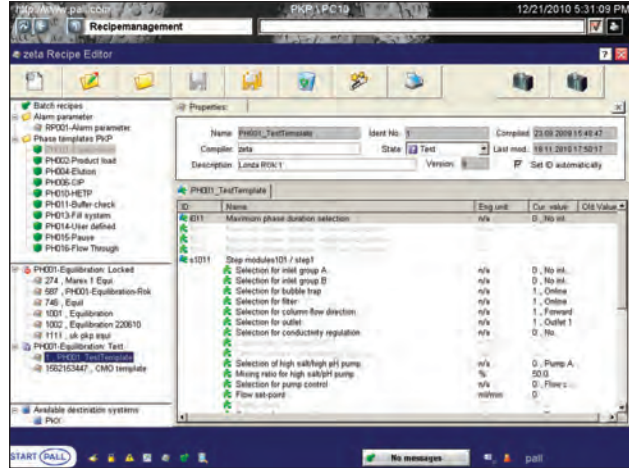
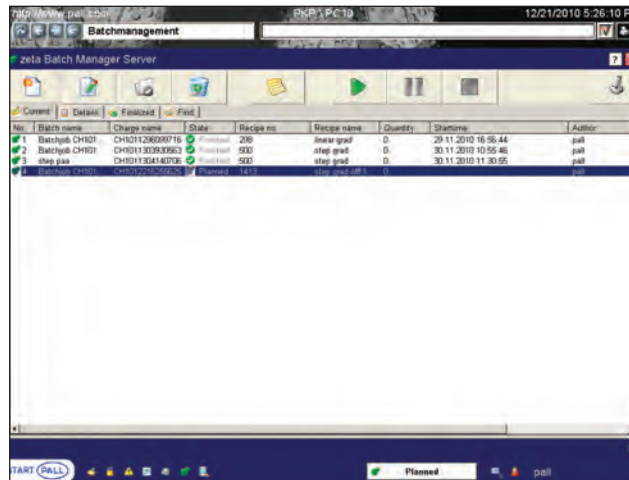

Figure 5
Batch management



System Components

Self Priming Four-piston Diaphragm Pump with Minimized Pulsation

- ▢ Single head design for low hold-up volume
- ▢ Two pumps for precise gradient formation and in-line buffer dilution
- ▢ Pump flow range: 17 - 2500 mL/min (system dependent)

Figure 6a
Self Priming Four-piston Diaphragm Pump



Figure 6b
UV, Conductivity and pH sensors



Figure 7a
PKP System Automation P&ID

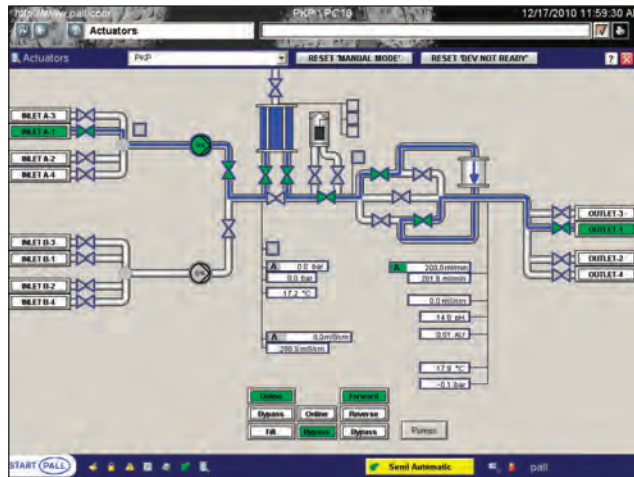

PKP Chromatography System Overview

	PKP1	PKP2	PKP3
Diameter, ID mm (in.)	3.2 (1/8")	6.3 (1/4")	9.5 (3/8")
Pump Flow Rate (L/h)	1 - 20	1 - 100	1 - 150
Maximum Pipe Velocity (m/s)*	1.7	1.7	1.0
Gradient/In-line Dilution		5 - 95% > 20 L/h 10 - 90% > 10 L/h 20 - 80% > 5 L/h**	
Process Connection	Inlets 4" (12 max) / Outlets 4 (14 max) *Per pump		
Column Flow Control	forward, reverse, by-pass		
Uncrated Weight	80 Kg (176 lb)		
Maximum Operating Pressure	6 barg (87 psi)		
Maximum Temperature	2 - 60 °C (36 - 140 °F) for production; up to 80 °C (176 °F) for CIP		
Pumps	2 x four-piston diaphragm		
Dimensions WDH, mm (in.)	600 x 600 x 1500 (23.6 x 23.6" x 59")		

*Maximum limited by pipe velocity (< 2 m/s)

**Limited by minimum pump flow rate (17 mL/min)

PKP System Standard Options

- ▣ Bubble trap including by-pass valve block, vent valve and level switches
- ▣ Additional inlets and outlets
- ▣ In-line filter, including by-pass valve block
- ▣ Air sensor at inlet
- ▣ Pre-column conductivity
- ▣ Post-column pressure sensor
- ▣ Second wavelength
- ▣ Mobile stainless steel trolley
- ▣ Drip trays for inlets and outlets

Instrument Specifications

Instrument	Type	Measuring Range / Accuracy
Flow Measurement	Magnetic-Inductive	System Range ± 0.5% MR
Air Sensor	Ultrasound	N/A
Pressure Sensor	Piezoresistive Transducer	-1 - 9 bar ± 0.5% MR
Temperature Sensor	Resistance Thermometer Pt1000	0 - 100 °C (32 - 212 °F) ± 0.5 °C (32.9 °F)
Conductivity Measurement	Conductive	0 - 200 mS ± 5% MR
pH Measurement	Potentiometric	pH: 0 - 14 ± 0.14
UV Measurement	Absorption Measure	0 - 3 AU ± 1% Reproducible 0 - 2 AU with 2 Wavelengths

Table of Wetted Components

Process Wetted Parts	Materials
Bubble Trap End Plates; Pump Pistons, Pressure, pH/cond/UV Flow Cell, Pipework, Valve Bodies, Conductivity Probe Electrodes	316 L Stainless Steel (Ra ≤ 0.6 µm, electro polished)
Tri-clamp Gaskets, Valve Diaphragms, Bubble trap seals, pump Seals/ Check valves, Instrument Seals, and Filter Seals	FDA conforming EPDM
Air Sensors	316 L Stainless Steel
Bubble Trap Tube	Borosilicate Glass (HALAR [®] coated for shatter protection)
pH Probe	Glass
Flowmeter	316 L/PFA Liner
Pump Diaphragms	Santoprene
UV-windows	Sapphire
Conductivity Body	PEEK

Ordering Information

Documentation

Pall's PKP chromatography systems are supplied with a comprehensive documentation package. To support validation efforts and efficient commissioning, IQ and OQ protocols are available as an option. In addition Pall can also provide support for execution of the protocols.

PKP system documentation includes:

- ▣ Operators manual
- ▣ Materials data sheets
- ▣ Certificate of conformity
- ▣ Comprehensive parts list and certification
- ▣ Mechanical and electrical diagrams
- ▣ Spare parts recommendation
- ▣ Maintenance recommendation

Your Pall representative can help you optimize your process requirements. Listed below are standard systems; however, other configurations and options are available to meet your process requirements. For additional information, or to order a PKP chromatography system, please contact your local Pall Life Sciences representative.

Chromatography Process Solutions from Pall

Scale up systems available from Pall

The PK solution platform and PKP Chromatography System range incorporates proven component technology, delivering accurate precision gradients as well as in-line buffer dilution. Maintaining the performance necessary to make your chromatography process consistent from batch-to-batch and optimal at pilot and manufacturing scales. Covering a range from 1 < 4000 L/h, Pall's PK and PKP systems ensure robust operation and flexibility for all bi chromatography applications. These systems can be used with Resolute chromatography columns as well as Mustang[®] chromatography membrane capsules.

System	PK10	PK25	PK50	PK100	PK300
Flow Range (L/H)	10 - 100	25 - 400	50 - 1000	100 - 2000	300 - 4000



Process Chromatography Columns

Resolute[®] DM and DP columns are ideally suited for process purification in the biopharmaceutical industry. A patented nozzle valve provides all column functions required for packing, unpacking, and running of the column in a closed system. Standard column diameters range from 280 mm to 1200 mm – all with selectable bed heights from 100 mm up to 600 mm. Resolute FM columns are purpose

designed glass columns for the manufacturing of clinical batch material or small scale production. Column diameters are 100, 140 and 200 mm with a bed height span of 100 mm to 460 mm.

Based on established and well-proven design, the Resolute column range provides improved column performance and true linear scalability combined with reproducible column packing methods for today's high performance media.

Resolute FM Column Range with Corresponding PKP Systems

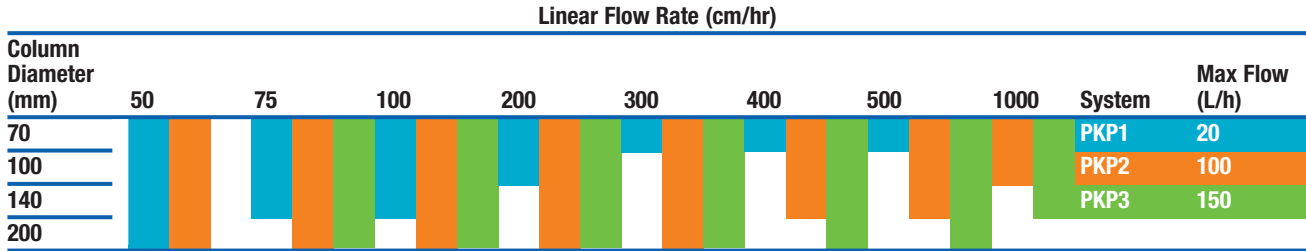

Membrane Chromatography

Mustang[®] Ion-exchange Membrane Chromatography Capsules, from Pall, deliver a flexible solution in bioprocessing, with scalable devices that can be used either as single- or multiple-use products. High volumetric flow rates lead to increased throughput, and the simple, easy-to-use compact design enables reduced buffer consumption in addition to overall process economic improvements. Mustang membrane products are ideal for efficient contaminant removal and capturing large target molecules (plasmid DNA, viral vectors, etc.).

Chromatography Sorbents

A large range of scalable, high productivity sorbents are available as Ion Exchangers (Q, S HyperCel, Q, CM, DEAE and S Ceramic HyperCel) and Mix-mode sorbents (MEP, HEA, and PPA HyperCel). Please contact your local Pall Life Sciences representative for additional information.





Life Sciences

United States

800.717.7255 toll free (USA)
516.484.5400 phone
516.801.9548 fax
biopharm@pall.com E-mail

Europe

+44 (0)23 9230 3303 phone
+44 (0)23 9230 2506 fax
BioPharmUK@europe.pall.com E-mail

Filtration. Separation. Solution.SM

Visit us on the Web at www.pall.com/biopharm

E-mail us at biopharm@pall.com

International Offices

Pall Corporation has offices and plants throughout the world in locations such as: Argentina, Australia, Austria, Belgium, Brazil, Canada, China, France, Germany, India, Indonesia, Ireland, Italy, Japan, Korea, Malaysia, Mexico, the Netherlands, New Zealand, Norway, Poland, Puerto Rico, Russia, Singapore, South Africa, Spain, Sweden, Switzerland, Taiwan, Thailand, the United Kingdom, the United States, and Venezuela. Distributors in all major industrial areas of the world.

The information provided in this literature was reviewed for accuracy at the time of publication. Product data may be subject to change without notice. For current information consult your local Pall distributor or contact Pall directly.

© 2011, Pall Corporation. Pall,  and Mustang are trademarks of Pall Corporation. ® indicates a trademark registered in the USA and TM indicates a common law trademark. *Filtration. Separation. Solution.* is a service mark of Pall Corporation. □ HALAR is a trademark of Solvay Solexis.

1/11, PDF, GN10.4200

USD2775